



Variable Optical Delay Line (VDL Series)

Rev 11H

Description

Variable Optical Delay Line provides precision optical path variation of more than 15 cm (500 ps). The compact, rugged design makes the device ideal for integration in network equipment, test instruments, and optical coherence tomography (OCT) systems for precision optical path length or timing alignment.

Specifications

Parameter	Unit	Values
Center Wavelength (λ_c)	nm	1060, 1550
Operation Wavelength	nm	$\lambda_c \pm 50$
Optical Delay Range	ps	0 - 500 ps Continuous
Zero Point Delay Offset	ps	~ 440
Readout Scale Resolution	mm	0.02
Max. Insertion Loss	dB	1.2
Max. Insertion Loss Variation	dB	0.5
Max. PDL	dB	0.1
Min. Extinction Ratio (for PM model)	dB	20
Min. Return Loss	dB	50
Max. Optical Power Handling (Continuous Wave)	mw	300
Operating Temperature	°C	0 to + 40
Storage Temperature	°C	- 40 to + 60
Fiber Type	-	Singlemode or PM Panda Fiber

¹IL is 0.5 dB higher, RL is 5 dB lower and ER is 2 dB lower for each connector added, measured at center wavelength

²Absolute delay at 0 ps setting measured to the edge of the enclosure (excluding caps, boots, and pigtails).

Package Dimensions

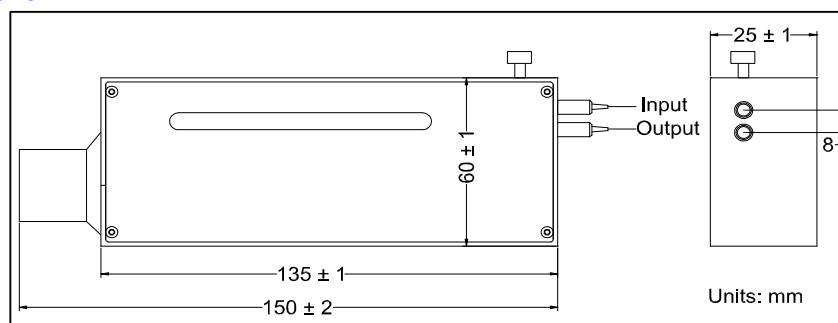

Ordering Information

VDL-①①①①-②②②-③-④-⑤-⑥-⑦

①①①①: Wavelength

1060 - 1060 nm

1310 - 1310 nm

1550 - 1550 nm

②②②: Delay Range

500 - 500 ps

③: Attenuator

A - Attenuator

N - None

④: Connector Type

1 - FC/UPC

2 - FC/APC

3 - SC/UPC

4 - SC/APC

N - None

S - Specify

⑤: Fiber Jacket

B - 250 μ m Bare Fiber

L - 900 μ m Loose Tube

3 - 3 mm Cable

S - Specify

⑥: Fiber Length

1 - 1.0 m

S - Specify

⑦: Fiber Type

S - Singlemode Fiber

P - PM Panda Fiber