

RIO ORION™ Series 1550nm Low Phase Noise Narrow Linewidth Laser Module

Data Sheet
July 2021

Key features

- Single longitudinal mode
- Center wavelength: 1530nm-1565nm, ITU-T DWDM 100 GHz C-band or custom
- Very low phase noise
- Very narrow linewidth, long coherence length
- Ultra-low RIN
- Excellent SMSR
- Unmatched wavelength stability over life and temperature
- Wavelength tunability
- Direct power modulation
- Very low sensitivity to vibration and acoustic noise
- SMF and PM fiber pigtail options
- Compact size, low power dissipation
- Easy to set-up and use
- Digital controller and firmware with multiple interface options (SPI, RS-232, RS-485)
- Telcordia GR-468 qualified
- RoHS compliant

Applications

- Acoustic & seismic interferometric fiber optic sensing
- Defense and security
- Oil & Gas – exploration and production
- LIDAR
- Metrology
- RF and microwave photonics
- Coherent Communications



Description

The ORION™ devices are compact laser modules employing the RIO high-performance External Cavity Laser (ECL). This laser design is based on RIO's proprietary planar technology (**PLANEX™**) and consists of a gain chip and a planar lightwave circuit including waveguides with Bragg gratings, forming a laser cavity with significant advantages.

The ORION™ modules provide a stable, self-contained, easy-to-use alternative to complicated, environmentally sensitive and expensive fiber laser sources, or other narrow linewidth laser alternatives.

The ORION™ module uses reliable, Telcordia qualified and industry proven components, and employs low noise, digital laser bias current and temperature control circuitry to set and monitor laser performance. External monitoring and control can be accomplished via standard interfaces, using RIO-supplied software. The ORION™ module is an ideal source for commercial and other fiber optic sensing applications, such as interferometric and Brillouin DTSS systems for oil & gas, security and smart infrastructure monitoring, coherent Doppler LIDAR for wind measurements, coherent and heterodyne metrology, photonic velocimetry and vibrometry, and coherent communications.

Absolute Maximum Ratings

Operation of the device beyond these maximum conditions may degrade device performance, lead to device failure, shorten product lifetime, and invalidates the device warranty.

Parameter	Min	Max	Unit
Storage temperature	- 40	+ 85	°C
Module supply voltage		5.5	V
ESD-susceptibility		500	V
Fiber bend radius	35		mm
Tensile strength, fiber to the package		5	N

Optical and Electrical Specifications

At recommended TEC set temperature T_s and bias current I_b

Parameter	Symbol	Condition	Min	Typ	Max	Unit
Output Optical Power	P_{out}	CW	See ordering information			mW
Power Stability over case temperature range ¹	dP_{out}	0 to +70 °C		±10		%
		+10 to +55 °C		±5		
		≤ ±1 °C			±0.3	
Center Wavelength (ITU grid)	λ	± 40 pm standard ²	1530		1565	nm
Wavelength tuning range ³	$\Delta\lambda_T$	via TEC temperature change	30 ⁴			pm
Wavelength stability over case temperature range ¹	$d\lambda$	0 to +70 °C		±10		pm
		+10 to +55 °C		±5		
		≤ ±1 °C			±0.5	
Frequency stability ⁵	ν_{t1}	Free running, over 1 hour		± 2	± 4	MHz
	ν_{t8}	Free running, over 8 hours		± 3	± 6	
Relative Intensity Noise	RIN	≥ 1kHz			-140	dB/Hz
		≥ 500 kHz	Shot noise limited			
Side Mode Suppression Ratio	SMSR	CW, at specified P_{out}	40			dB
Optical S/N Ratio	S/N	From spontaneous noise levels at +/-1 nm from λ	60			dB
Polarization Extinction Ratio ⁶	PER	For PM option, polarization and connector key aligned to slow axis	20			dB
Optical Isolation	ISO		40			dB
Voltage Supply	V_{cc}		4.75	5	5.25	V

1. Customized power and wavelength stability requirements are available upon request.
2. Customized center wavelength and build tolerance, including ITU-T C-band is available. See ordering information page.
3. Phase continuous wavelength tuning by changing TEC temperature settings. Some performance parameters will change over tuning range.
4. Tuning range is not symmetric around center wavelength, 30pm range is +10pm to -20pm as a minimum. Customized extended wavelength tuning range available upon request up to +/-45pm.
5. After 1 hour stabilization, tested with heterodyning of two lasers at constant case temperature.
6. With PM-fiber PANDA option. See ordering information page.

Modulation Specifications: Low Frequency [LF] (for both option RIO01XX- & RIO03XX-)

Parameter	Symbol	Condition	Min	Typ	Max	Unit
Frequency modulation bandwidth ¹	f_{mL}	Sinusoidal modulation	DC		100	kHz
Frequency tuning efficiency ^{1, 2}	η_{mL}	Sinusoidal modulation at 10 kHz	25 ³	50		MHz/V
Tuning voltage magnitude ¹	V_{tuneL}		-4		+4	V
Output power modulation index ^{1, 4}	M_L	Sinusoidal modulation at 10 kHz; wavelength tuning 100 MHz p-p		5	10 ⁵	%

1. Via pin4 of ORION D-9 connector
2. Tuning efficiency will vary over modulation bandwidth. Contact RIO for more information.
3. If this modulation feature is ordered with a grade 4 or grade 5 phase noise spec, this min spec value decreases to 20 MHz/V.
4. Frequency modulation will lead to modulation of output power.
5. If this modulation feature is ordered with a grade 4 or grade 5 phase noise spec, this max spec value increases to 15%.

Modulation Specifications: High Frequency [HF] (for option RIO03XX- only)

Parameter	Symbol	Condition	Min	Typ	Max	Unit
Frequency modulation bandwidth ¹	f_{mH}	Sinusoidal modulation, AC coupled	0.01	100	200	MHz
Frequency tuning efficiency ^{1, 2}	η_{mH}	Sinusoidal modulation at 20 kHz	100	200		MHz/V
		Sinusoidal modulation at 500 kHz	25	50		
		Sinusoidal modulation at 20 – 200 MHz	50	100		
Tuning voltage magnitude ¹	V_{tuneH}	AC coupled			1	V_{p-p}
Output power modulation index ^{1, 3}	M_H	Sinusoidal modulation at 100 MHz; wavelength tuning 100 MHz			4	%

1. Via 50 Ω , SMC connector
2. Tuning efficiency will vary over modulation bandwidth. Contact RIO for more information.
3. Frequency modulation will lead to modulation of output power.

Linewidth and Phase Noise Specifications

At recommended TEC set temperature T_s and bias current I_b ,

Parameter	Symbol	Conditions	Grade 1	Grade 3	Grade 4	Grade 5 ³	Unit
Spectral Linewidth, FWHM ¹	$\Delta\lambda_L$		≤ 15	≤ 5	≤ 2	≤ 1	kHz
Phase Noise Typical Values ²	PhN	@ 10 Hz	123	41	20	10	$\mu\text{rad}/\text{rt-Hz}$ 1 m OPD
		@ 200 Hz	22	8	4	2	

1. Value based on Lorentzian linewidth model.
2. As measured with RIO's interferometric phase noise test setup, 1m OPD in the SM fiber.
3. 10 mW output power version only.

Thermal Specifications

Parameter	Symbol	Condition	Min	Typ	Max	Unit
Operating temperature range (case) ¹	T_c		0		+ 70	$^{\circ}\text{C}$
Power Dissipation	P_{dt}	At 50 $^{\circ}\text{C}$ case temperature		4		W
Power Dissipation	P_d	Over case temperature range			6	W
Total current	I_{max}	Over case temperature range			1.5	A

1. Custom case temperature range available upon request.

Connectors

#	Description
A	FC/APC connector on pigtailed fiber
B	Interface D-9 Female connector for power supply, external monitoring and control
C	Option for RIO03XX-, RF connector (SMC female), 50 Ω impedance

Interface connector B

Pin #	Function SPI	Function RS-232	Function RS-485	Note
1	Vcc +5V	Vcc +5V	Vcc +5V	4.75 V Min, 5.25V Max, Regulated, Low noise (<100mVp-p)
2	MISO (output)	Tx	Data +; 1 k Ω diff impedance	
3	MOSI (input)	Rx	Data -; 1 k Ω diff impedance	
4	Modulation (input)	Modulation (input)	Modulation (input)	1 k Ω impedance
5	GND	GND	GND	
6	/Ready-Warning (output)	/Ready-Warning (output)	/Ready-Warning (output)	Active low (Ready), needs external pull up
7	/SPI SS (input)	Not used	Not used	
8	SPI CLK (input)	Not used	Not used	
9	/Enable (input)	/Enable (input)	/Enable (input)	12K internal pull up to Vcc (active low)
Configuration	4-wire SPI slave. Bit order: MSB first. Bit rate: <= 2 MHz . MISO and MOSI: 3.3V drive, TTL level compatible, data centered on rising clk. /SS: Slave Select (active low). CLK: Idle state is low, data clocked on rising edge.	9600 Baud. 8 Data Bits. No Parity Bit. 1 Stop Bit. No Flow Control. TTL asynchronous serial option available at request	9600 Baud. 8 Data Bits. No Parity Bit. 1 Stop Bit. No Flow Control.	

Mechanical Diagram

A. For both option RIO00XX- and RIO01XX-

Units: Inch

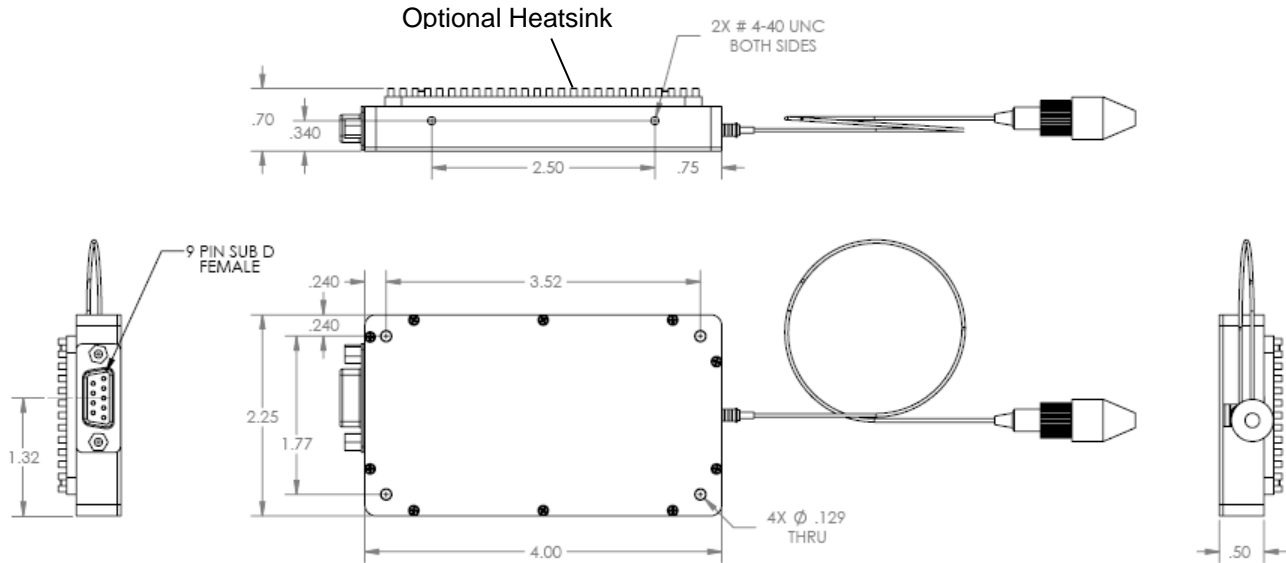

B. For option RIO03XX-

Units: Inch

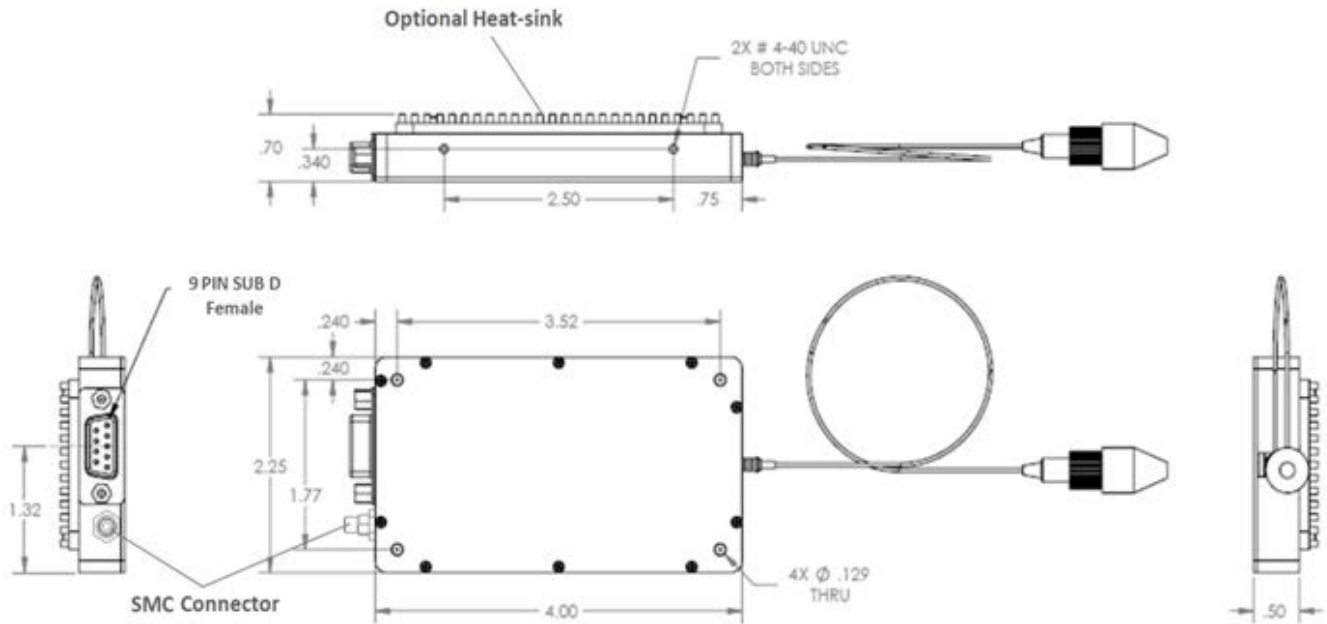

ORION Housing Material:

- Electroless Nickel-plated Aluminum

Reliability and Certifications

- Qualified according to Telcordia GR-468-CORE
- CE certified
- UL certified

Ordering Information

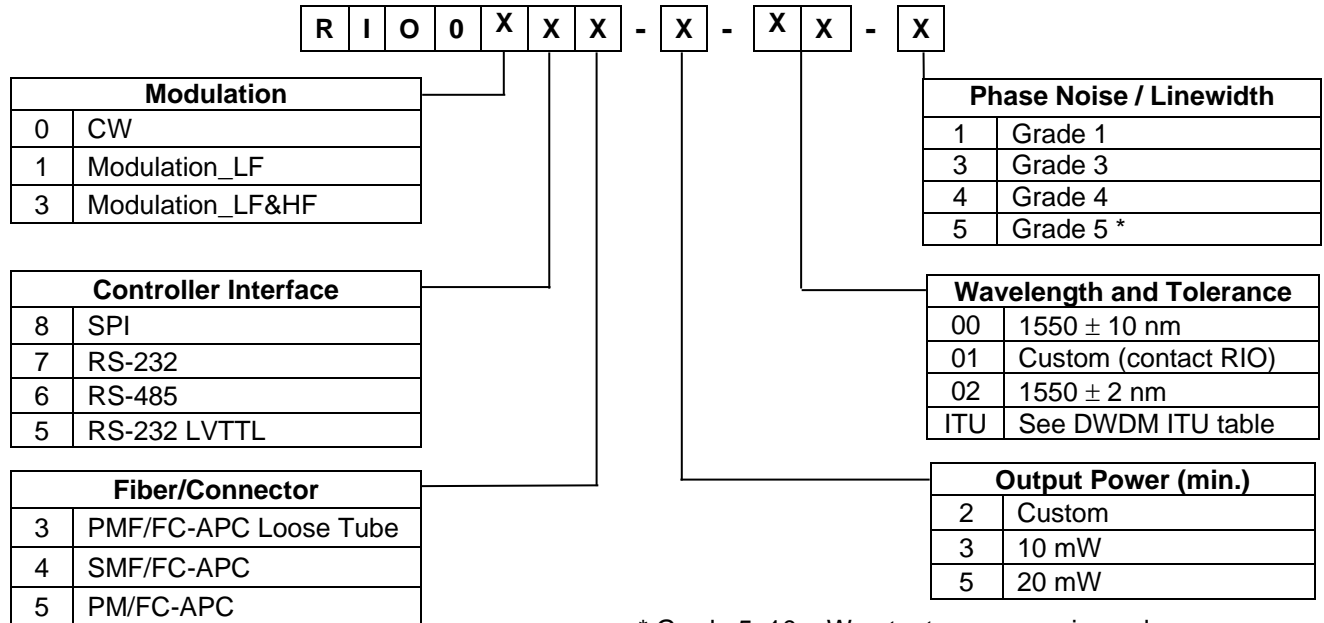

* Grade 5: 10 mW output power version only

Accessories

Accessory PN	Description
RIO008X-KIT	5V DC power supply, GUI software & USB/SPI adaptor with interface cable
RIO018X-KIT	5V DC power supply, GUI software & USB/SPI adaptor and interface cable (w. BNC port for modulation)
RIO038X-KIT	5V DC power supply, GUI software & USB/SPI adaptor and interface cable (w. BNC port for modulation) & SMC-SMA cable
RIO007X-KIT	5V DC power supply, GUI software & RS232 interface cable
RIO017X-KIT	5V DC power supply, GUI software & RS232 interface cable (w. BNC port for modulation)
RIO037X-KIT	5V DC power supply, GUI software & RS232 interface cable (w. BNC port for modulation) & SMC-SMA cable
RIO006X-KIT	5V DC power supply, GUI software & RS485 interface cable
RIO016X-KIT	5V DC power supply, GUI software & RS485 interface cable (w. BNC port for modulation)
RIO036X-KIT	5V DC power supply, GUI software & RS485 interface cable (w. BNC port for modulation) & SMC-SMA cable
RIO0HS	External heatsink w/ hardware



DWDM ITU Wavelength¹

ITU channel number	ITU Frequency THz	Wavelength nm	ITU channel number	ITU Frequency THz	Wavelength nm	ITU channel number	ITU Frequency THz	Wavelength nm
15	191.50	1565.50	30	193.00	1553.33	45	194.50	1541.35
16	191.60	1564.68	31	193.10	1552.52	46	194.60	1540.56
17	191.70	1563.86	32	193.20	1551.72	47	194.70	1539.77
18	191.80	1563.05	33	193.30	1550.92	48	194.80	1538.98
19	191.90	1562.23	34	193.40	1550.12	49	194.90	1538.19
20	192.00	1561.42	35	193.50	1549.32	50	195.00	1537.40
21	192.10	1560.61	36	193.60	1548.51	51	195.10	1536.61
22	192.20	1559.79	37	193.70	1547.72	52	195.20	1535.82
23	192.30	1558.98	38	193.80	1546.92	53	195.30	1535.04
24	192.40	1558.17	39	193.90	1546.12	54	195.40	1534.25
25	192.50	1557.36	40	194.00	1545.32	55	195.50	1533.47
26	192.60	1556.55	41	194.10	1544.53	56	195.60	1532.68
27	192.70	1555.75	42	194.20	1543.73	57	195.70	1531.90
28	192.80	1554.94	43	194.30	1542.94	58	195.80	1531.12
29	192.90	1554.13	44	194.40	1542.14	59	195.90	1530.33

1. Standard wavelength build tolerance is +/-40pm. Custom build tolerances as tight as +/-5pm available upon request.

Laser Safety Information

The ORION laser module is classified as FDA/CDRH Class IIIb laser products per CDRH, 21 CFR 1040 laser safety requirements, and complies as Class 3R laser product per international standard IEC 60825-1, 2014.

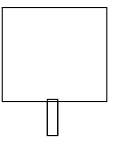
 <p>DANGER</p> <p>INVISIBLE LASER RADIATION AVOID DIRECT EYE EXPOSURE</p>  <p>OUTPUT POWER: 50 mW max WAVELENGTH: 1.53~1.57 μm BEAM DIVERGENCE AT FIBER OUTPUT: 0.21 rad CLASS IIIb LASER, CDRH, 21 CFR 1040 CLASS 3R LASER, IEC60825-1</p>	<p>LASER APERTURE</p>  <p>AVOID EXPOSURE Invisible laser radiation is emitted from end of fiber or connector</p>
--	---