



## Mini Type Manual Variable Attenuator (MVOA Series)

### Description

Rev 11B

Mini Type Manual variable Attenuator (MVOA) operates by manually moving a shading element into optical beam. The shading element can be adjusted to get any attenuation value in a range. MVOA features low insertion loss, good resolution, integrating high stability and good reliability. It applies for pre-emphasis attenuation, transmitter power control, in-line power equalization, and amplifier power control, etc.

### Specifications

Parameter	Unit	Value
Center Wavelength ( $\lambda_c$ )	nm	780 or 850      980 or 1064
Operating Wavelength Range	nm	$\pm 10$ $\pm 20$
Max. Excess Loss	dB	1.0      0.6
Max. WDL, 23 °C, minimum attenuation	dB	0.3
Min. Attenuation Range	dB	30
Resolution within 10 dB Attenuation Range	dB	0.1
Min. Extinction Ratio (for PM Fiber Type)	dB	20
Max. PDL (for SM Fiber Type), 23 °C, $\lambda_c$ , Minimum Attenuation	dB	0.05
Max. TDL at Attenuation Range, $\lambda_c^2$	dB/°C	0.01
Min. Return Loss (for SM or PM Fiber)	dB	50
Min. Return Loss (for MM fiber)	dB	25
Max. Optical Power (Continuous Wave)	mW	300
Operating Temperature	°C	0 to + 70
Storage Temperature	°C	- 40 to + 85

<sup>1</sup>IL is 0.5 dB higher, RL is 5 dB lower, and ER is 2 dB lower for each connector added.

<sup>2</sup>TDL is exempted when attenuation value over 30dB.

### Package Dimensions

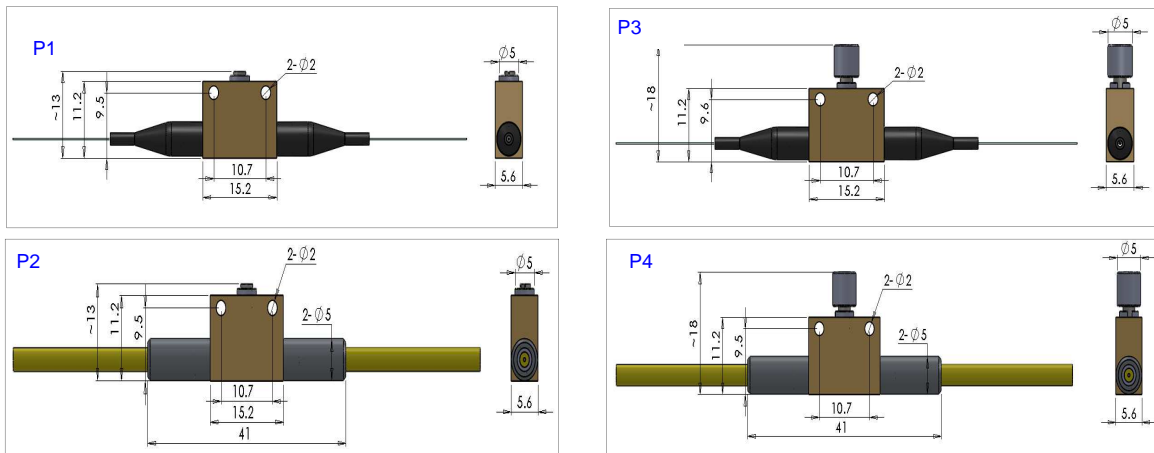

Screwdriver type

Manual type

Tolerance: x —  $\pm 1$  mm ,x.x —  $\pm 0.1$  mm

<sup>1</sup>Package type P1&P3 is designed for 250 um or 900 um fiber jacket and Package type P2&P4 is designed for 2mm or 3 mm fiber jacket.

### Ordering Information

MVOA-①①①①-②-③-④-⑤-⑥

①①①①: Wavelength

- 780 - 780  $\pm$  10 nm
- 850 - 850  $\pm$  10 nm
- 980 - 980  $\pm$  20 nm
- 1064 - 1064  $\pm$  20 nm
- S - Specify

②: Fiber Type

- H - HI Fiber
- P - Panda Fiber
- M1 - 105/125 N.A. 0.22
- M5 - 50/125
- M6 - 62.5/125
- S - Specify

③: Connector Type

- 1 - FC/UPC
- 2 - FC/APC
- 3 - SC/UPC
- 4 - SC/APC
- N - None

④: Fiber Jacket

- B - 250 um Bare Fiber
- L - 900 um Loose Tube
- C - 3 mm Cable
- 2 - 2 mm Cable

⑤: Fiber Length

- Q - 0.75 m
- 1 - 1.0 m
- S - Specify

⑥: Package Type

- P1 - Turn with Screwdriver
- P2 - Turn with Screwdriver
- P3 - Turn with Manual
- P4 - Turn with Manual