



## Polarization Maintaining Tap Coupler (PMTC Series)

Rev 10

The PMTC Series is manufactured by using advanced technology to allow the input signal to be splitted at various ratios with high extinction ratio.

### Specifications

Parameter	Unit	Value	
Center Wavelength	nm	1310 or 1550	
Operating Wavelength Range	nm	$\lambda_c \pm 40$	
Configuration		1 × 2	2 × 2
Max. Excess Loss	dB	0.7	1.1
Max. Uniformity (only for 50%)	dB	0.6	0.8
Tap Ratio	%	1 ± 0.2%, 2 ± 0.4%, 4 ± 0.8%, 5 ± 1.0%, 10%, 20% and 50%	
Min. Return Loss	dB	50	
Min. Extinction Ratio	dB	20	20
Max. Optical Power (Continuous Wave)	mW	300	
Max. Tensile Load	N	5	
Operating Temperature	°C	-5 to +70	
Storage Temperature	°C	-40 to +85	

Fiber Type

SMF-28 or PM Panda fiber for tap port  
PM Panda fiber for input & output ports

\*IL is 0.3 dB higher, RL is 5 dB lower, and ER is 2 dB lower for each connector added. Connector key is aligned to slow axis.

### Package Dimensions

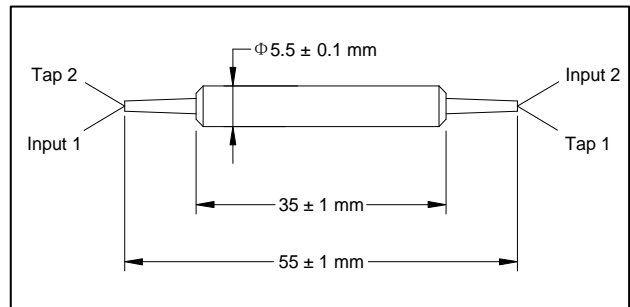
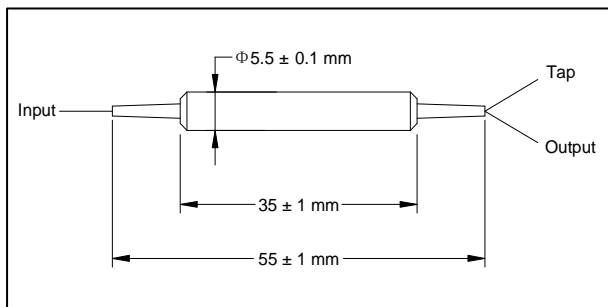

### Ordering Information

PMTC-①①-②-③③-④-⑤-⑥-⑦-⑧

①①: Wavelength

31 - 1310 nm

55 - 1550 nm

SS - Specify

③③: Coupling Ratio

01 - 1/99

02 - 2/98

04 - 4/96

05 - 5/95

10 - 10/90

20 - 20/80

50 - 50/50

SS - Specify

④: Connector Type

1 - FC/UPC

2 - FC/APC

3 - SC/UPC

4 - SC/APC

N - None

⑤: Fiber Jacket

B - 250 μm Panda fiber

L - 900 μm loose tube

S - Specify

⑥: Fiber Type for Tap Port

M - SMF-28

P - Panda fiber

S - Specify

⑦: Fiber Length

Q - 0.75 m

S - Specify

⑧: Working Axis

F - Fast axis blocked