



1064 nm High Power Polarization Maintaining Isolator (HPMI Series)

Rev 10 B

The 1064 nm High Power Polarization Maintaining Isolator is characterized with low insertion loss, high isolation, high power handling, high return loss, excellent environmental stability and reliability. It is ideal for fiber laser and instrumentation applications.

Specifications

Parameter	Unit	Grade P	Grade A
Center Wavelength (λ_c)	nm	1064 nm or specify	
Min. Extinction Ratio	dB	20	20
Typ. Peak Isolation	dB	35	33
Min. Isolation, λ_c , 23 °C, all polarization states	dB	30	28
Typ. Insertion Loss, 23 °C	dB	1.3	1.6
Max. Insertion Loss, 23 °C	dB	1.6	1.9
Min. Return Loss (Input/Output)	dB	50/50	45/45
Max. Optical Power (Continuous Wave)	W	1	
Max. Tensile Load	N	5	
Fiber Type		PM 980 Panda fiber	
Operating Temperature	°C	0 to +50	
Storage Temperature	°C	-20 to +75	

Package Dimensions

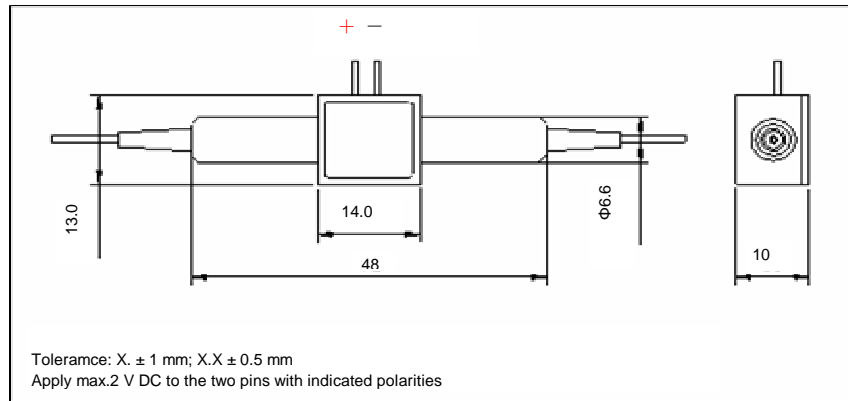

Ordering Information

HPMI1-①①-②-③-④-⑤-⑥

①①: Wavelength

06 - 1064 nm

SS - Specify

②: Grade

P - Premium

A - A grade

③: Connector Type

N - None

④: Fiber Jacket

B - 250 μ m Panda fiber

L - 900 μ m loose tube

S - Specify

⑤: Fiber Length

Q - 0.75 m

S - Specify

⑥: Working Axis

F - Fast axis blocked

B - Both axes working