



## 2 μm Polarization Maintaining Isolator (PMI Series)

Rev 11

The 2 μm Polarization Maintaining Isolator is designed and manufactured according to Telcordia standard. The unique manufacturing process and optical path epoxy-free design enhance the device high power handling capability. The device is characterized with high performance, high reliability. It was designed specially for 2 μm laser system.

### Specifications

Parameter	Unit	Single Stage	Dual Stage
Center Wavelength (λc)	nm	2000	
Min. Extinction Ratio	dB	18	18
Min. Isolation, λc ± 50 nm, 23 °C, all polarization states	dB	16	35
Max. Insertion Loss, λc ± 20 nm, all temperature, all polarization states	dB	1.2	1.5
Min. Return Loss (Input/Output)	dB	50	50
Max. Optical Power (Continuous Wave)	W	1 or 2	
Max. Peak Power for ns Pulse	kW	10	
Max. Tensile Load	N	5	
Fiber Type		PM 1550 Panda fiber	
Operating Temperature	°C	-5 to +70	
Storage Temperature	°C	-40 to +85	

\*IL is 0.3 dB higher, RL is 5 dB lower, and ER is 2 dB lower for each connector added. Connector key is aligned to slow axis.

\* The Optical Power is 1W only for connector added.

### Package Dimensions

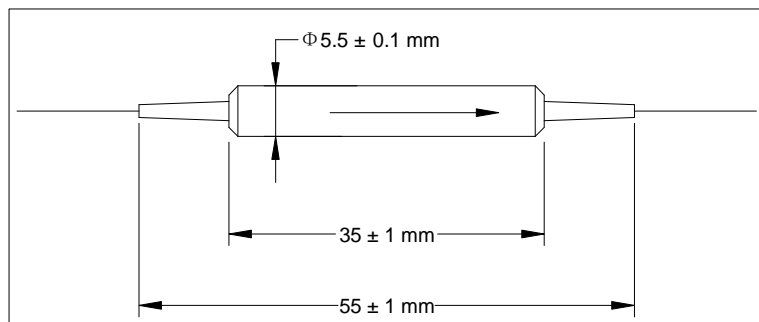

### Ordering Information

PMI-①①①①-②-③-④-⑤-⑥-⑦-⑧

①①①①: Wavelength 2000 - 2000 nm SSSS - Specify	②: Handling Power 1 - 1 W 2 - 2 W S - Specify	③: Stage 1 - Single Stage 2 - Dual Stage	④: Connector Type 1 - FC/UPC    4 - SC/APC 2 - FC/APC    N - None 3 - SC/UPC    S - Specify
⑤: Fiber Jacket B - 250 μm Panda fiber L - 900 μm loose tube S - Specify	⑥: Fiber Length Q - 0.75 m S - Specify	⑦: Working Axis F - Fast axis blocked B - Both axis working	⑧: Power Type P - Pulse Application C - Continuous Wave