



Polarization Maintaining Filter Wavelength Division Multiplexer (PMFWDM Series)

Rev 11

The 2 μm Filter Wavelength Division Multiplexer series is based on environmentally stable thin film filter technology. The devices combine or separate light at different wavelength in a wide wavelength range. They offer very low insertion loss, low polarization dependence, high isolation and excellent environmental stability. High power handling capability can be achieved through unique pigtail processing and high quality AR coating.

Specifications

Parameter	Unit	Value
Pass Band	Wavelength Range	nm
	Typ. Insertion Loss	dB
	Max. Insertion Loss	dB
	Typ. Isolation	dB
	Min. Isolation	dB
Reflection Band	Wavelength Range	nm
	Typ. Insertion Loss	dB
	Max. Insertion Loss	dB
	Typ. Isolation	dB
	Min. Isolation	dB
Min. Return Loss	dB	50
Max. Polarization Dependent Loss	dB	0.2
Typ. Polarization Dependent Loss	dB	0.1
Thermal Stability	dB/°C	0.005
Max. Optical Power (Continuous Wave)	mW	300
Max. Tensile Load	N	5
Fiber Type	PM 1550 fiber (all ports) or PM 1950 fiber (all ports)	PM 1550 fiber for reflect port and PM 1950 fiber for common & pass port
Operating Temperature	°C	-5 to +70
Storage Temperature	°C	-40 to +85

*IL is 0.3 dB higher, RL is 5 dB lower, and ER is 2 dB lower for each connector added. Connector key is aligned to slow axis.

Package Dimensions

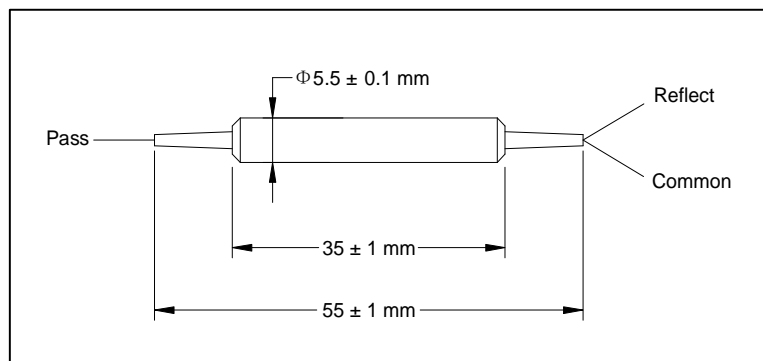

Ordering Information

PMFWDM-①①①①-②-③-④-⑤

①①①①: Wavelength

2057 - 2000 Pass/1570 Reflection

SSSS - Specify

⑤: Fiber Length

1 - 1.0 m

S - Specify

②: Connector Type

1 - FC/UPC

2 - FC/APC

3 - SC/UPC

4 - SC/APC

N - None

S - Specify

③: Fiber Type

1 - PM 1550 fiber (all ports)

2 - PM 1950 fiber (all ports)

3 - PM 1550 fiber for reflect port
and PM 1950 fiber for common
& pass port

④: Fiber Jacket

B - 250 μm bare fiber

L - 900 μm loose tube

S - Specify